

WEIGHT: 135 LBS.
 CAPACITY: 50 GALLONS
 NOTE: Not to Scale. All dimensions are based on manufacturers and industry standards of $\pm 3/8$ inch.

UPDATED: 3/10

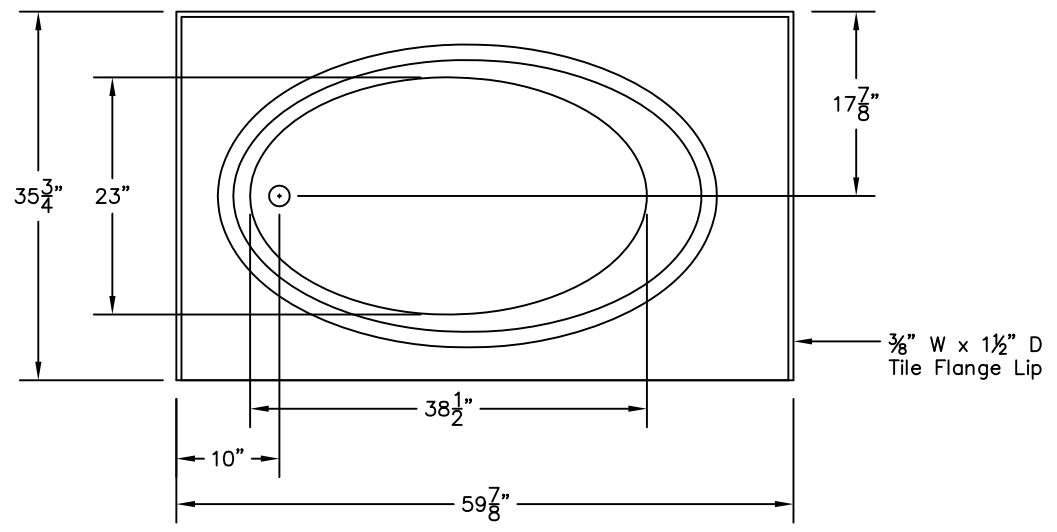

TOP VIEW

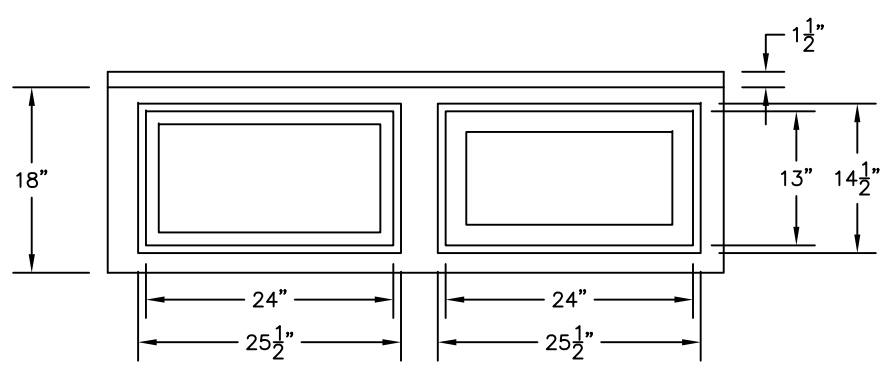

SIDE VIEW

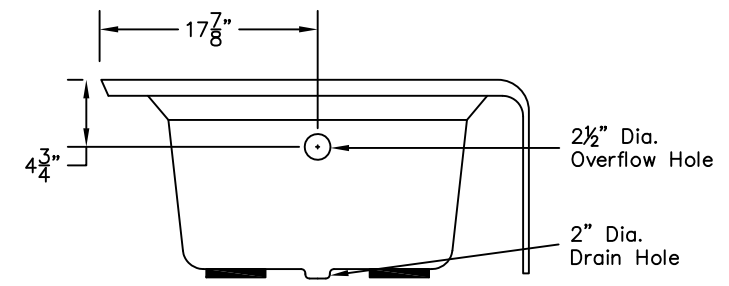

END VIEW



CANYON