

WEIGHT: 189 LBS.  
 CAPACITY: 60 GALLONS  
 NOTE: Not to Scale. All dimensions are based  
 on manufacturers and industry standards  
 of  $\pm 3/8$  inch.

UPDATED: 10/06

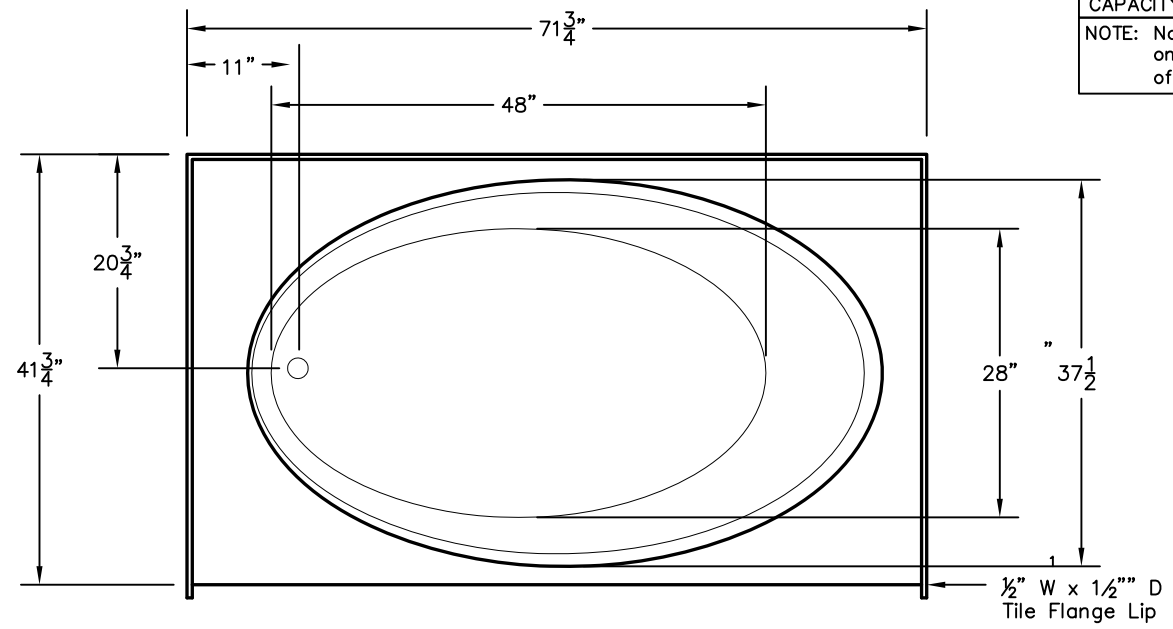

TOP  
VIEW

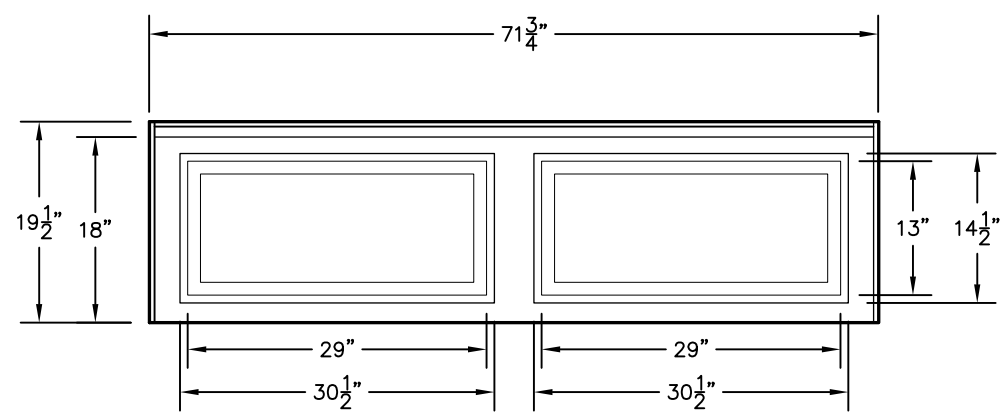

SIDE  
VIEW

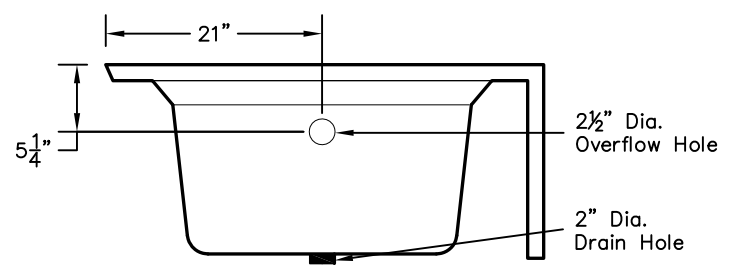

END  
VIEW



**KINGSLEY**